

BMW CCA CLUB RACING - 2001 RULES

<i>BMW CCA CLUB RACING - 2001 RULES</i>	1
<i>General Rules</i>	4
<i>Safety</i>	8
<i>Car Classification</i>	12
Stock and Prepared Classes	12
Stock Classes	14
Prepared Classes	20
Modified & Super Modified Classes	23
Historic Class	25
<i>CLASS STRUCTURE</i>	26
<i>PROTESTS AND APPEALS</i>	27
Rules Clarifications	28
<i>RULE CHANGES</i>	30
Club Racing Rules Committee	30
Club Racing Advisory Committee (CRAC)	30
<i>APPENDIX A - Roll Cage Specifications</i>	32
<i>APPENDIX B – Electrical Disconnect Specifications</i>	34
<i>Appendix C - Minimum Weights</i>	35
<i>Appendix D - ENDURO SUPPLEMENTAL RULES</i>	37

2001 Rules - Page 1



Preface

The overall philosophy at each BMW CCA Club Racing Event will be the same: *"A competitive driving experience for all BMW CCA enthusiasts, in any/all types of BMW's in a fun, safe, and friendly environment where the primary emphasis is on clean driving and machinery preservation."* This philosophy will be maintained by common rules and procedures and the BMW CCA Club Racing Stewards at each event.

These rules are intended to be simple, easy to read and brief. It has never been the intent of the administrators of BMW CCA Club Racing to write an epistle similar to the General Competition Rules of the SCCA. It is our wish that competitors follow the charter of BMW CCA Club Racing and adhere to the spirit of competition that has developed.

The **STOCK** class is intended for those cars typically seen at drivers schools owned by an enthusiast who has done simple modifications to improve the basic performance of a stock, street driven BMW. As outlined in the rules, suspensions may be modified by adding performance components. The engine may only be modified in that chips for the fuel injection system may be changed. All other modifications to the vehicle are intended for safety purposes only.

The **PREPARED** class is intended to invite vehicles prepared for SCCA Improved Touring competition into BMW CCA Club Racing. In order to accommodate those enthusiasts with modified, street driven vehicles, some compromises beyond the SCCA regulations have been incorporated into these rules. The intent of this class is to allow the more progressive enthusiast and the experienced racer to participate in BMW CCA Club Racing with a higher level of preparation that is still street licensable, street drivable and in keeping with the spirit of the "original" vehicle.

MODIFIED AND SUPER MODIFIED - Those wishing to build "full blown" race cars have two classes to compete in. Vehicles in the Modified classes have the option of full race suspensions, unlimited modifications to the BMW engine and BMW

transmission. Super Modified is intended for pro series cars (i.e. Super Touring, SCCA World Challenge cars).



General Rules

1. **Philosophy** - The BMW CCA Club Racing Program is designed to be fun, safe and competitive. Good sportsmanship, honesty, and a sense of fair play should exist at all BMW CCA Club Racing events.
2. **13/13 RULE** - The "13/13 rule" of vintage racing will be in effect at all BMW CCA Club Racing program events. Conduct which jeopardizes safety or results in dangerous or damaging situations will not be tolerated. Under this rule, any single or multi-car incident which results in car damage will, at the discretion of the Competition Steward, cause the following:
 - A. The BMW CCA Club Racing Competition and Technical Stewards will collect and review all information relating to the incident, including corner worker and other observer reports, driver statements, and damage reports in order to make a determination of fault and assess penalties.
 - B. A driver who is found to be at fault will be:
 1. Excluded from competition for the remainder of the event at which the incident occurs. For a multi-day event, the Steward's determination may be for the entire event or the balance of the race day in which the incident occurs.
 2. Placed on probation for a thirteen (13) month period. If during this probation period the driver is involved in another contact incident, competition privileges will be suspended for thirteen (13) months.
 3. For SINGLE CAR incidents the event Competition Steward is authorized at his discretion to assess penalties of 3, 6, or 13 months probation. If the driver is on probation from a previous incident, then a 13 month suspension will be assessed.
 4. Subject to suspension from the next BMW CCA Club Racing event in which they could have competed.
 5. Excluded from the event results or listed as "DQ".
 6. Excluded from any event points or awards that may otherwise be available
 7. For the event, any racer currently on probation MUST attend any/all scheduled "Rookie" meetings at the next race they participate in.In addition, a penalty may be assessed by the event Competition Steward for any infraction of the rules, incident, or personal conduct that is not in keeping with the spirit and intent of BMW CCA Club Racing.

The following are examples of actions that could warrant penalty:

2001 Rules - Page 4



1. passing under yellow or red flag
2. blocking
3. technical rules infraction
4. unsportsmanlike conduct (both on and off track)
5. reckless and dangerous driving

The addition of penalties for passing under yellow (or red) flags, blocking, technical rules infractions, unsportsmanlike conduct, and reckless and dangerous driving is intended to emphasize the focus on SAFETY and good sportsmanship that are the tenets of BMW CCA Club Racing. Assessment of penalties for these incidents will be based on evaluation by the event Stewards of the competitor's attitude and behavior. For example, blocking may initially incur a furred or waved black flag warning.

Repeated violation and/or additional incidents will, at the discretion of the event Competition Steward, result in a penalty up to and including probation or suspension.

Any driver involved in an on track incident causing visible damage to their or another driver's car must report to the event Technical Steward with the car (if drivable) within 30 minutes of the checker flag of the session in which damage incurred. Failure to do so will subject the driver to penalty.

All incidents shall be resolved as soon as practical after the incident is reported/observed with the objective being resolution and assessment of penalty at the event.

Drivers penalized will be notified in writing of the penalty assessed. Drivers are required to present notice of such penalty to race Competition Stewards at any races they participate in while the penalty is in effect.

3. **Driver Eligibility** - Only BMW CCA Club Racing Program "licensed" drivers are eligible to compete.
4. **Unlisted Modifications** - Any modification not specifically listed is not allowed. **In other words, if the rules don't say you can do it - DON'T.**
5. **Stock classes** are based on factory published horsepower, torque, weight and gearing. All cars must conform to these figures if tested. The BMW CCA Club Racing Stewards reserve the right to test any car for conformance.
6. **Eligible Vehicles** - Only BMW manufactured automobiles, using BMW manufactured chassis, engine case and transmission case, and factory approved race cars and modifications are eligible. (Documentation of factory

approval is the responsibility of the car owner). Tube frame construction cars are allowed in modified classes.

7. CAR NUMBERS, CLASS IDENTIFICATION, DECALS:

- A.** All cars must display easily readable numbers and class designation for identification. These must be displayed on each side and front (hood) of the vehicle, of significant size and color differentiation from the body color so as to be clearly seen by timing and scoring officials. Numbers shall be a minimum of 8 inches high with a 1-1/2 to 2 inch stroke. Class identification shall follow the numbers and be a minimum of five inches high. Class identification will consist of 2 letters, i.e. A-Modified = AM, I-Prepared = IP, J-Stock = JS. Identification for a car in Super Modified will be the letters SM.
- B.** Competitors may request assigned numbers from the National Registrar. The goal will be to allow racers to use requested numbers. Where duplications exist, deference will be given to the racer with the lowest Club Racing license number (as long as he/she is a paid registrant at least two weeks before an event date). Race officials reserve the right to assign car numbers for specific events.
- C.** Club Racing officials may require series and sponsor identification (decals) in specific size, contrast and placement to be displayed on cars before being allowed to race.

- 8. Steward's Decisions** - Any decisions of the BMW CCA Club Racing Stewards concerning safety, eligibility, acceptance, etc., are binding. Vehicles entered in the program must, in addition to meeting safety and classification rules and regulations, be presented in an attractive and eye pleasing manner. BMW CCA Club Racing Stewards reserve the right to refuse to accept any vehicle which they feel does not "conform to the spirit" of the BMW CCA Club Racing Program.
- 9. Reclassification** - BMW CCA Club Racing National officials reserve the right to reclassify a car and driver based upon a review of previous performance.
- 10. Award Eligibility** - Vehicles must compete in the class to which they are classified to be eligible for awards.

NOTE:

No express or implied warranty of safety or fitness for a particular purpose shall result from publication of, or compliance with, these rules and/or regulations



which are intended as a guide for the sport and are in no way a guarantee against injury or death to participants, spectators or others.

2001 Rules - Page 7



Safety

These safety regulations are adapted from various racing organizations. If you are in doubt as to an interpretation, ask, or follow SCCA specs for an IT, production or GT class car. If you are going to err, do so on the side of being too safe!

1. TECH INSPECTION

- A. **EVENT TECH** - all cars must be comprehensively prepared prior to arrival at the track. At the track all entrants must pass a tech inspection of all car and driver safety equipment and meet all the safety requirements of the BMW CCA Club Racing Program.
- B. Any vehicle deemed unsafe by BMW CCA Club Racing Stewards will not be allowed to compete.
- C. **TECH FOR RULES COMPLIANCE, WEIGHING** - Tech Stewards may require onsite detailed tech inspection for rules compliance including weighing any car entered in a race and/or may announce detailed tech of entries in a specific class or classes at a race.
- D. **IMPOUND** - In order to promote careful adherence by all competitors to the car classification and preparation rules, Club Racing Stewards reserve the right to conduct impound and inspection of the first three cars in any or all classes immediately at the conclusion of each race. Cars found to be at variance with the class rules will be denied their finishing positions, and the variances will be recorded in the individual log books.
- E. **Inspection by Stewards** - Tech Stewards may request disassembly and inspection of any entered car to ascertain its compliance with these rules. If the car is found to be in compliance Club Racing shall stand the expense of disassembly, inspection and reassembly. If found not to be in compliance the competitor shall bear these expenses.

- 2. **HELMETS** rated with a SNELL automotive rating of SA-90 or newer are required. (Snell **M** rated helmets are **not** allowed). Drivers of vehicles without full windshields are required to have either full face helmets with shield in place or use protective goggles. It is strongly recommended that **all drivers** wear either full helmets with shield in place or protective goggles. Driver information required on helmet: Drivers name, blood type, allergies, and date of last tetanus.
- 3. **ROLL CAGES** - all classes require full roll cages. A horizontal brace is required in the rear hoop. All cages must be mounted metal-to-metal, of

approved materials and of proper size as listed in Appendix A. Side impact “doorbars” may be added to any cage and the drivers door panel may be modified or removed to accommodate them. Side impact bars may be bolt-in or removable configuration.

A. **STOCK** class roll cages shall be bolted or welded into the car, shall be contained entirely within the driver/passenger compartment, and shall include six (6) attachment points as shown in Appendix A. Two (2) additional bars may be extended from the front cage downbar to the front wheel well to protect the driver's feet/legs. Carpet/padding may be cut for roll cage installation (installation **MUST** be metal to metal). Rear braces may pass thru interior trim panels. Cage tubing cannot be welded or bolted to the sides or roof and cannot be attached to stiffening devices in trunk or engine compartment.

NOTE: Stock class car cages may **NOT** include braces to the rear shock towers. The few cars that were approved with this configuration will be grandfathered and allowed to remain in Stock IF they submit documentation in writing to the National Technical Steward including copies of log books, etc. proving they had been authorized this construction for Stock class. The NTC will respond in writing; such authorization must remain in the car's log book. Without such documentation cars will compete in Prepared classes.

B. **PREPARED** class - Main hoop braces may be mounted at the rear shock mounts/towers or suspension pickup points. Such rear braces may pass through any rear bulkhead or panel separating the driver/passenger compartment from the trunk/cargo area/fuel tank/fuel cell area, provided the bulkhead or panel is sealed around said cage braces.

C. **MODIFIED and SUPER MODIFIED** - cage construction is free provide it complies with the basic structure outlined in Appendix A.

4. **SAFETY HARNESS** - 5 or 6 point competition harness (with 2” sub belt), no more than five years old and meeting SFI-16.1 standards, properly mounted, are required. Harness cannot be mounted to the seat or seat rail. Mounting must be to the chassis backed by large diameter washers or to the roll bar. No two harness straps can be attached to a single mounting bolt. No Y-type shoulder harnesses are allowed.

The shoulder harness straps must be mounted such that the angle of the straps from the driver's shoulders to the anchor point must not be above horizontal nor at an angle greater than 40 degrees below horizontal. The anti-submarine straps should be mounted such that they will not allow upward

vertical movement of the lap belt due to “crushing” of the front seat cushion in any situation.

The design of some seats can, in many cases, render the shoulder harness straps ineffective as they slide from the shoulders under lateral loading. It is, therefore, mandatory that seats which do not allow the shoulder harness straps to remain on the shoulders in all situations be modified with a slot for the harness straps to pass through, or be replaced with a racing seat which has provisions for routing the straps. This is a mandatory modification which must be completed before the vehicle will be eligible to compete. A “sternum strap” or similar solution is allowed, but is not a substitute for proper shoulder strap arrangement

5. **DRIVING SUITS** - One piece fire retardant driving suit is highly recommended. (Minimum requirement: Two layer or one layer plus fire retardant underwear). Three layer or two layer with SFI rating of 3.2A/5 strongly recommended. Military flight suits are not acceptable substitutes for fire retardant driving suits.) Fire retardant socks and gloves are required. Driving shoes of a fire retardant material are strongly recommended. Tennis shoes with all leather uppers are acceptable. Drivers with mustaches and/or beards must wear a balaclava.
6. **FIRE SAFETY** - a 2 lb. or larger fire extinguisher with a 10 B/C rating, securely metal-to-metal mounted in the cockpit in a safe location, and reachable to the driver while seated and restrained, is required. An on-board fire system is strongly recommended. Cars competing in the Modified and Super Modified classes on full race tires, i.e. slicks, require on-board fire systems with a minimum of two nozzles. One for the engine compartment and one for the driver's area. Cars with on-board fire systems require E decals. All fire bottle safety pins must be removed so that the system is ready to activate.
7. **WINDOWS, WINDOW NET** - Both front door windows must be completely down and an approved window net and attachment system fitted to the driver's window area. **The window net must be attached to the cage and NOT to the door. Holes must not be drilled in the cage to mount the window net. All window nets must be a minimum of 17"x21" and SFI 27.1 rated.** Net design must allow for quick one-handed removal. The net must be mounted securely at the top or bottom with provision for easy removal at the opposite edge in the event of an accident. The use of plastic tie wraps or straps is not allowed. **Tinted REAR windows are specifically disallowed in all classes and their use is discouraged in all windows. OEM window tinting is allowed. The purpose of**

this rule is to address dark aftermarket tinting which causes real safety issues in driver awareness and communication.

8. **OPEN CARS - ARM RESTRAINTS** - open cars (incl. convertibles with top up or down or with hardtop) must be equipped with approved arm restraints.
9. **SEATS, SEAT BACK BRACES** -
 - A. **SEAT BACK BRACES** - Seat back bracing is required in all classes, attached to the horizontal tube on the rear hoop of the cage. Braces must either be bolted securely to the seat utilizing a metal plate of no less than 12 sq. inches to distribute the load, **OR**, if not bolted to the seat, a brace of similar minimum dimensions must be in contact with the seat back. **Minimal** energy absorbing padding is allowed between the brace and seat back. It is recommended that if not attached to the seat the brace be designed where possible to wrap around both sides of the seat to prevent lateral movement. Contact Regional Technical Stewards with any specific application questions.
 - B. **REPLACEMENT SEATS** - any replacement drivers seat must meet or exceed the strength and rigidity of the factory installed seat.
 - C. **Hardware** - the minimum diameter of all seat fastening hardware must be 8 mm. 2002's, 530i's and early 320i's must upgrade the original 6 mm hardware. It is strongly recommended that the seat mounting pads on these early cars be strengthened to withstand the loads of racing.
 - D. **Headrests**, either integral with the seat or separate, are required. The headrest must extend above the midpoint of the back of the helmet on the vertical plane of the seatback with the driver in the normal seating position.
10. **Neck Support** - padded nomex covered neck supports are recommended.
11. **Airbags and Steering Wheels** - Non-standard steering wheels are allowed in all classes. Airbags may be disconnected during ontrack sessions in all classes and may be removed from the stock steering wheel.
12. **Rear Bulkhead** - a metal bulkhead between the passenger compartment and the trunk or compartment containing the fuel tank is required on cars using a fuel cell or where the fuel tank is not totally under the car floor (ie: is required in 1600/2002 models). Such a bulkhead is recommended but not required on cars where the fuel tank is under the body (ie: E36).
13. **Sunroofs** must remain completely closed.
14. **Floor mats** must be removed. Drivers side carpet may be removed.
15. **Hubcaps, trim rings, etc.** must be removed.
16. **Lugnuts** must be original manufacturer specification with engagement at least equal to the diameter of the wheel lug studs. Use of **wheel studs** to replace lugbolts is allowed.

17. **Oil lines** - All oil lines on the pressure side of the oil pump must be thread-on connections equal to or better than the factory, i.e. NO slip-on oil lines to coolers, gauges, etc.
18. An **electrical cut-off switch**, with standard approved decal, mounted externally preferably on the driver's side - is strongly recommended for all cars and is required for cars competing in Modified and Super Modified classes on full race tires, i.e. slicks. The switch must disconnect the battery from all circuits, (except an electronically operated fire system) and must shut off the engine (and alternator) while it is running. Method of operation can be by pull wire, requiring no external body modification. (See Appendix C)
19. **Catch tank** for radiator overflow and oil breather (if vented into the atmosphere) is mandatory.
20. **SOUND LEVEL** - All competitors' cars **must not exceed a maximum sound emission level of 105 dB** as measured from a distance of 50 ft from the edge of the track. More restrictive standards may apply from track to track. Competitors bear sole responsibility to determine that their vehicles comply with Sound Control Regulations at each event. Mufflers may be required.
21. **Engine Coolant** - Use of an ethylene glycol (coolant) substitute (e.g. "Water Wetter") is encouraged for all competitors. Ethylene glycol may be used when deemed necessary for climatic reasons.
22. **PERSONAL MEDICAL IDENTIFICATION** - Club Racing recommends use of personal medical information (worn by drivers) and endorses the TrakMed system (www.trakmed.com). The rules package will contain further information on the TrakMed product and a special BMW CCA Club Racing offer. For the 2001 series use of the TrakMed system or equivalent is strongly recommended. Your safety is our (and should be your) first priority!

Car Classification

Stock and Prepared Classes

1. General

Any vehicle in the stock and prepared classes must compete with full road equipment and, with the exception of exhaust/emissions, be street legal, and capable of being registered for street use in the condition of the car when presented at scrutineering, and be capable of being driven to and from the event.

Cars in these classes are to be factory equipped vehicles as delivered to the general public through United States dealerships. No special order performance enhancements are allowed as stock. Evolution parts are considered modifications and may only be interchanged with stock parts as allowed in class rules. Eurospec cars will be classified a minimum of one stock or prepared class up from an American spec model.

Vehicles competing in SCCA "Amateur" classes (Improved Touring, Touring 1, Touring 2 and Showroom Stock) can participate in BMW CCA Club Racing adhering to either BMW CCA class rules or SCCA class rules, but not a combination of both. Competitors must declare which series preparation rules they are complying with and be prepared to present the applicable rule book. Log books documenting participation in **SCCA ITA/B/C/S, Touring 1 or 2, or Showroom Stock A/B/C** classes are required for cars running under SCCA IT, Touring or Showroom Stock configurations OR entrants must conform to BMW CCA class rules. The logbook does not have to be current; documentation will be noted in the BMW CCA logbook. Stewards may allow a one time, one race exemption noted in the BMW log book.

Cars complying with Touring or Showroom Stock specs will be classed in the appropriate **Stock** class. **Cars complying with ITA/B/C/S specs will be classed in the appropriate Prepared class. ITE cars will generally be classed as Modified.**

2. Approved Weights

STOCK AND PREPARED CLASSES - APPROVED WEIGHTS

All cars in the stock and prepared classes must meet or exceed the minimum weight as specified in Appendix E. The cars may be measured as they come off the track from qualifying and/or race sessions. A car found to be underweight after a qualifying session must add securely mounted ballast in the passenger compartment to meet the minimum weight requirement or choose to move to a higher class for that single event. The vehicle will be moved to the back of the starting grid for the race. A car found to be underweight after a race session will be disqualified from race results.

A notation will be made on the current event page of the vehicle logbook. The car shall be weighed at the next event and meet minimum weight requirements before being allowed to compete.

Current weight limits are based on published BMW NA weight as stated in the owner's manual for year and model of the vehicle. *Competitors are requested to provide this information at the technical inspection.*

Stock Class vehicles are measured without the driver and must meet published BMW factory weight.

Prepared Class vehicles are measured with the driver in the vehicle and total weight must meet allowed weight.

For Prepared Class cars **(ITA, ITB, ITC and ITS)** for which SCCA has published minimum weights for 2001, those weights apply.

For endurance races, the minimum weight shall be measured with the lighter of the registered drivers in the car.

Stock Classes

Updating or backdating is allowed provided the converted vehicle meets all specifications of vehicle to which it is converted.

1. Engine

- A. As delivered from factory. No modifications of any type after the air filter or before the exhaust port.
- B. Stock, for the year, fuel injection must be retained, except carburetors may be substituted for mechanical fuel injection. Carbureted cars may substitute up to maximum of 40mm downdraft. Modifications to the intake manifold to accept a 40mm downdraft are allowed.
- C. Control module chips are free in all classes.
- D. Exhaust system must be in stock configuration and function as intended for make, model and year. Catalytic converters must be intact and functional (if originally so equipped). Headers are prohibited (unless originally equipped).
- E. Machining for balancing purposes only is allowed.
- F. All pistons must be factory replacement spec and match factory dome, dish, valve relief configuration, ring geometry, weight, wrist pin height; compression must meet factory replacement specifications. A maximum of .020 (.5mm) overbore is allowed.

NOTE: Rebuilding of E30 M3 engines to 2.5L using EVO III crankshaft and pistons is allowed, but moves the car up one class. Use of entire E30 M3 EVO III 2.5L motor moves the car to Modified class.

- G. Air conditioning belts and air injection systems may be removed.
- H. Engine, transmission, and differential oil coolers are free. Coolers must meet the following specific minimum installation requirements.
 - 1. all coolers mounted below the factory water radiator must be protected from debris intrusion with steel screening.
 - 2. any hose or line passing through any part of a bulkhead or panel must be grommeted to prevent abrasion.
 - 3. hoses must be properly anchored to the body or panels at least every ten (10) inches using protective, cushioned line clamps or factory type line retainers.
 - 4. SAE Pressure safety factor will be a minimum 4 to 1 factor (if your engine develops a max oil pressure of 100 psi use hose that has a minimum 400psi working pressure.
 - 5. hose shall be temperature rated to 300 degrees F.

6. all non factory coolers shall be isolation mounted to eliminate stress cracking.
 7. No slip-on or push-on connections are allowed.
- I. Accusumps and oiling system changes - Accusumps and modifications to the oil pump pick-up, baffle and oil pan are permitted. E36 6 cylinder cars may use the M3 LTW dual pick-up oil pump/pan kit.
 - J. Motor & Transmission Mounts can be changed for increased strength using alternate BMW factory parts; must be same height as stock for the model year and options of the vehicle.
 - K. Gauges are free **(see 10 Data Acquisition).**

2. Suspension

- A. Suspension pick-up points must remain in stock location and type. Any suspension component that is not adjustable from the factory or by approved factory service manual procedures may not be adjusted.
- B. Upper front shock mounts must be OEM factory parts; factory camber correction mounts ("crash mounts") are allowed. Solid mounts +/- substitute bushing material are prohibited. A fixed camber plate that fits between the unaltered strut assembly and the unaltered body and provides no adjustment is allowed. An upper strut mount assembly is not a camber plate. The car must be equipped with the factory original upper front strut mount. It must be used without modification to the part. The body holes locating and securing the mount must be UN-altered and used in the original configuration to secure the mounting. No slotting, modification or substitutes are permitted.
- C. Shock absorbers are free providing they are of the same type, using the same pick-up points, as supplied by the factory.
- D. Any suspension setting not requiring machining or modification to factory parts is allowed (adjustable coil overs are prohibited).
- E. Spring type and outside diameter must remain as supplied by factory.
- F. Spring rates are free.
- G. Sway bar sizes and configurations are free (including adjustable bars).
- H. Suspension bushing materials are free (other than upper front shock mounts - see B).
- I. Any bolt-in shock tower brace is allowed.
- J. Additional welding of sway bar pick-up points and trailing arm pick-up points for reinforcement and safety is allowed. Pick-up points must remain

as per factory placement. Front sub-frame, motor mount areas, control arm pick-ups, idler arm and steering box mounts can be strengthened for safety with additional welding.

- K. **E36 M3 front lower control arms and bushings, along with solid rear upper shock mounts are allowed, in the interests of safety and durability. It is strongly advised that this modification is made.**

3. Tires and Wheels

- A. Any DOT approved, nationally marketed, generally available, "road race version" tire is allowed. "V" or higher speed rated tires are required for all cars, except those for which "V" rated tires are not universally available. In all cases, the speed rating of the tire must be equal to or greater than the speed potential of the vehicle. No "autocross spec" tires are allowed.
- B. **Rain tires - Hoosier Dirt Stocker and Hoosier "Motorola Cup" rain tires may be used as rain tires. Requests for approval of any other rain tires can be submitted to the National Technical Steward.**
- C. Tread must have adequate rubber to ensure safely completing the full race session.
- D. Any tire deemed "unsafe" by the BMW CCA Club Racing Stewards will be disallowed and the car will be prohibited from participation until the problem is resolved to the approval of the Stewards.
- E. Wheel type and style is free (except for width and diameter restriction see E and F) providing wheel meets or exceeds factory safety specs.
- F. Wheel width - One (1) inch wider than originally supplied wheel and any tire combination which fits under the stock body without modification exceeding "rolling" or "grinding" of the outer fender lip is allowed. 1600, 2002 models may use up to 7" width (with the same bodywork restrictions).
- G. One (1) inch larger than originally supplied diameter is allowed. Vehicles with TRX tires/wheels as stock may upgrade to 16".

4. Brakes

- A. Brake pad material is free.
- B. Brake calipers and rotors must be of the same type and size as original for the model and year of the car.
- C. Grooving and slotting of rotors is allowed.
- D. Ducting of air to rotors is allowed.

- E. Removal of dust shields (backing plates) is allowed.
- F. Brake fluid is free.
- G. Master Cylinders must be as supplied by the factory, except that early production cars (i.e. 1600, 1800 and 2002) may update to tandem master cylinder for the safety of the dual circuit system.
- H. **Brake lines may be steel or aeroquip.**

5. Differential

- A. Ratios of ring and pinion, case size and number of side cover bolts must be as supplied by the factory for the model year, transmission type and options of the car.
- B. Factory limited slip differentials are allowed with the same ring and pinion ratio as the standard differential.
- C. Finned, larger capacity differential covers may be used.

6. Transmission/Flywheel Assembly

- A. U.S. Spec BMW OEM transmission, as originally equipped for the vehicle must be used. No changes permitted to the case or internals.
- B. Transmission coolers are free.
- C. Modification to, or substitution of, the shifter mechanism which reduces the range of motion is allowed.
- D. **Flywheel assemblies must retain stock configuration and weight.**

7. Body/Chassis/Interior

- A. Removal or substitution of components which alters weight distribution or reduces weight of vehicle is not allowed. Vehicle must meet minimum weight specification.
- B. Chassis/body, with the exception of spoilers, must be the same material as supplied by the factory.
- C. Ducting of air to rotors/engine - fog lights/covers may be removed to facilitate ducting of air to brake rotors/engine.
- D. Seats are free providing minimum weight of vehicle is met. Any ballast to meet weight, because of seat substitution, must be placed entirely in the driving compartment and be securely bolted to the chassis.
- E. Steering wheels and shift knobs are free.
- F. Spoilers are free providing they do not exceed maximum body width nor are one inch more than the maximum factory body length. Wings are

restricted to factory original, factory optional configurations, or aftermarket products not exceeding factory product dimensions. E30 M3s - may use aftermarket front one piece bumper/spoiler unit provided the original crash bar is maintained OR the assembly is otherwise reinforced to equal strength as the original assembly. E36 M3s - Front splitters are permitted but must not exceed the factory M3 LTW configuration.

- G. Modifications to the underside of the vehicle for the purpose of improving aerodynamics are not allowed.
- H. Interiors, with the exception of seats and the panels affected by the installation of the roll cage, must be intact . Passenger seat is required; rear seat back and seat base are required unless the roll cage installation precludes reinstallation. Headliners must remain in place.
- I. Spare tire, tools and associated assemblies may be removed (i.e. 318ti).

8. Fuel Cells

SCCA approved fuel cells may be used. Fuel cells shall be located within twelve (12) inches of the original fuel tank location. (An exception to this location requirement is any model where the original fuel tank is located beneath the rear seats). Additional reinforcement may be added to support the fuel cell but such reinforcement shall not be attached to the roll cage. Floor pan may be modified for installation. There shall be a metal bulkhead between the driver/passenger compartment and the compartment containing the fuel cell.

9. Electrical Fuel Pumps

A mechanical fuel pump may be replaced with an electrical fuel pump provided that it is wired to be controlled by the ignition system, to ensure shut down in the case of an accident requiring electrical cut-off.

10. Data Acquisition

Data acquisition devices are free in Stock (and Prepared) Classes, as long as they are NOT able to adjust ANY setting on the vehicle at ANY TIME by the driver while driving during practice, qualifying, or race conditions. These devices are to be used for information gathering ONLY.

Prepared Classes

Allowed Modifications in addition to those allowed in Stock Classes

1. Engine

- A.** A single carburetor may be substituted for fuel injection on 4 or more cylinder engines, two carburetors on 6 cylinder engines. Addition of a carburetor over original equipment or as stated above will result in the car being elevated one class. Modifications/changes to the intake manifold to accept additional carburetor(s) is allowed. Throttle bodies, air horns, intake plenums, mass air meters are free.
- B.** Camshaft lift and duration may be changed from stock. Cam gears and valve springs are free. No other internal engine changes are allowed.
- C.** Non-OEM ignition systems are allowed.
- D.** OBD II equipped cars may retrofit engine electronics to the pre-OBD II factory system which came on the same model and engine type. Aftermarket engine management systems (other than control module chips) are not allowed.
- E.** All pistons must be factory replacement spec and match factory dome, dish, valve relief configuration, ring geometry, weight, wrist pin height; compression must meet factory replacement specifications. A maximum of .040 (1mm) overbore is allowed. Compression ratio may be changed only within the tolerances effected by resurfacing for trueness.
- F.** Exhaust systems are free.
- G.** "Engine swap" cars will be classed based upon the engine. Providing that the car meets the weight minimum for the vehicle which the engine was originally designed. If unable to meet the weight requirements the car will be reclassified within the prepared classes based upon power to weight ratio, if possible. Otherwise the car will be moved to the modified classes.
- H.** Motor and Transmission mounts can be changed for increased strength - must be same height as stock for the model year and options of the vehicle. Fabricated solid mounts are allowed.

2. Suspension

- A. Adjustable front camber plates/slotting to achieve suspension settings is allowed. Pick-up points cannot be welded or machined for adjustment purposes.
- B. Rear camber adjustment is allowed.
- C. Height adjustable front coil-over setups mounted in the original location are permitted.
- D. Rear springs are free but must be mounted in the original location. Height adjustable rear coil-overs are allowed in cars originally equipped with coil-over suspensions.
- E. External reservoir shock absorber systems are allowed.

3. Tires and Wheels

- A. Any wheel and tire combination which fits under the stock body without modification exceeding "rolling" or "grinding" of the outer fender lip is allowed. Exception: 1600 and 2002 models may flare fenders.

4. Brakes

- A. Rotors are free (except carbon rotors are not allowed) with the following size limitation: 328mm (12.9") x 32mm (1 1/4").
- B. Calipers are free with the following limitations: 4 piston maximum, 2 piece design, 1 caliper per wheel.
- C. The number of master cylinders must be as supplied by the factory.
- D. Brake Drums are free (ie: 1600/2002 and 320 models).

5. Differential

- A. Ratio of the ring and pinion is free.
- B. Non-factory limited slip of any type is allowed.

6. Transmission

- A. BMW OEM transmission. as originally equipped or factory alternate transmission designed for the vehicle, must be used. No changes to the case or internals are permitted.

7. Body/Chassis/Interior

- A. Ducting for additional coolers allowed provided it doesn't change size and shape of factory panels.
- B. Spoilers and wings are free providing they do not exceed maximum body width and are no higher than the roofline.
- C. Interior may be removed, except dash and door panels providing the car "conforms to the spirit" of the BMW CCA Club Racing Program, i.e., it is aesthetically pleasing. Driver and passenger side door(s) panels may be altered or removed to accept side door impact bars. The OEM passenger door panel(s) may be replaced with 0.060" aluminum or comparable materials, securely attached to the door, as per the 2001 SCCA IT regs.
- D. All air conditioner components may be removed as long as vehicle meets minimum weight specification.

Modified & Super Modified Classes

Allowed modifications in addition to those allowed in Stock & Prepared Classes

Introduction

Any car which exceeds the modifications for the "STOCK" and "PREPARED" classes will compete in either the MODIFIED or SUPER MODIFIED CLASSES. The cars in these classes do not have to be street registerable, however, they must meet accepted safety requirements and the decision to be allowed to run rests entirely with the BMW CCA Club Racing Program personnel. Class for competition will be based on engine displacement.

Modified class is intended for the SCCA GT class car competing at the regional level of preparation which is designated for the amateur level and for cars that exceeds the level of modifications in the Prepared class.

Super Modified class is intended for the pro series cars that were built to compete in various professional racing series (i.e. IMSA GT, Super Touring and SCCA World Challenge etc.). The Event Stewards have the final decision on classification of entries as Modified or Super Modified, subject to appeal.

1. Engine

- A. Must retain a BMW OEM engine block or case. Other changes or modifications are free.
- B. Engine must run on approved gasoline. Nitrous oxide is not allowed.
- C. Turbocharging/Supercharging - For the purpose of engine size determination, turbocharging or supercharging increases engine size by a 1.5 factor.

2. Suspension

- A. Free, except that only Super modified cars can run cockpit adjustable sway bars.

3. Data Acquisition

- A. Engine and Suspension data acquisition is free.

4. Tires and Wheels

- A. Any tire and wheel combination meeting the safety requirements of the BMW CCA Club Racing Program technical inspectors is allowed.
- B. Tire and wheel package must be completely covered by the bodywork and have sufficient clearance to prevent rubbing which could be considered dangerous.
- C. Slicks - Full race tires, i.e. slicks, are allowed.

5. Brakes

- A. Free except carbon rotors are not allowed in Modified. Super Modified cars are free.
- B. Brake lights are required and must be as bright and as easily seen as stock brake lights.

6. Differential

- A. Free.

7. Transmission/Flywheel Assembly

- A. Modified cars must use BMW OEM transmission of any kind and ratio.
- B. Super Modified is free including sequential shifters.
- C. Flywheel lightening or replacement is allowed.

8. Body/Chassis/Interior

- A. Fenders may be flared to cover wheels and tires.
- B. Doors, fenders, hood, bumpers, and decklids may be replaced with fiberglass or composite materials.
- C. Cutting of non-stock openings and removal of headlights is allowed.
- D. Windows, with the exception of the windshield, may be replaced with alternate materials. Windshields may be replaced with polycarbonate of minimum 1/8" thickness. Supporting windshield bars are recommended.
- E. Removal of interior is allowed providing the car "conforms to the spirit" of the BMW CCA Club Racing Program (ie, is aesthetically pleasing).

2001 Rules - Page 24



- F. Front and rear windshield retaining clips are required for non-glass windshields.

Historic Class

This class is designed to be run under vintage “exhibition” rules as a separate race group if a sufficient number of entries and available scheduling allow. Eligible open wheel cars would be permitted in this class.

Cars in this class may be exempt from some safety regulations found in other racing classes, but will still be required to undergo a complete tech inspection.

Passing will be held to a minimum, only in designated zones and only with proper signaling from the driver of the car being overtaken.

Drivers must meet all series standards for licensing and safety equipment

The decision to be allowed to run in this class rests entirely with BMW CCA Club Racing personnel.



CLASS STRUCTURE

SUPER MODIFIED	MODIFIED	PREPARED	STOCK
As assigned	A: 3.5L and Up	H: E46 M3 , E36 M3 3.2L US, M3 Lightweight, M Roadster, M Coupe, M5, M6, 540, all 12 cyl, 745 Turbo	H: E46 M3 , E36 M3 3.2L US, M3 Lightweight, M Roadster, M Coupe, M5, M6, 540, all 12 cyl, 745 Turbo
	B: 3.0L - 3499CC	I: E46 330i/xi , E36 M3 3.0L U.S. except Lightweight, E30 M3 2.5L, Z3 2.8L	I: E46 330i/xi , E36 M3 3.0L U.S. except Lightweight, E30 M3 2.5L, Z3 2.8L
	D: 2.2L - 2999CC	J: E46 328, E36 328, E30 M3 2.3L, Z3 2.3L, E30 323	J: E46 328, E36 328, E30 M3 2.3L, Z3 2.3L, E30 323
	E: 1800CC - 2199CC	K: E46 323/ 325 , E36 323/325, E30 325i/is, 3.0csi, 3.0Si, 3.0V8, E28 535i	K: E46 323/ 325 , E36 325/325, E30 325i/is, 3.0csi, 3.0Si, 3.0V8, E28 535i
	F: 697CC - 1799CC	L: E36 318i/is/ti, E30 325e/es, E30 318is, Z3 1.9, 528, 2002tii	L: E36 318i/is/ti, E30 325e/es, E30 318is, Z3 1.9, 528, 2002tii
	G: Historic	M: Others 2.0L and under	M: Others 2.0L and under
	*Note: there is no class C Modified		

NOTE: For STOCK and PREPARED CLASSES the number of cylinders shall agree with the body type. For the MODIFIED CLASSES, displacement shall be no more than .75L larger than original for the stated model, exclusive of the 1.5x turbo multiplication factor.

PROTESTS AND APPEALS

Protests

1. A protest shall concern a decision, act, or omission of the organizers, officials, car, driver, or other person connected with the competition, which is considered to be a violation of these rules, except that a protest against a refusal of entry or license certification shall not be allowed. Each protest shall be accompanied by a fee of \$50.00 in cash.
2. Every protest shall be made in writing, specifying the protestee's car number, brief description of car, rules infraction with section number, etc. The protest shall be addressed to the Protest Committee and signed by at least one entrant. Protests should be submitted prior to qualifying or race sessions to allow proper reclassification, but must be submitted within 30 minutes of completion of the last timed run of the protested car. The fee shall be returned if, and only if, the protest is upheld; otherwise the fee will go to the BMW CCA Club Racing treasury.
3. The Protest Committee has the right to impound any car(s). It is the driver's responsibility to present his car as required. The car must remain unchanged until released by the Protest Committee.
4. Only another driver in the same class can protest a car. The protester may request that the car be dismantled, inspected, or any other test made, provided that, if a driver, they post a cash bond with the Protest Committee sufficient to cover the total expense of disassembly, inspection and reassembly. If the car shall be found upon inspection to conform to the rules, the protester shall forfeit the bond which shall be used to cover costs involved. If the car is found upon inspection not to conform to the rules, the protester's bond shall be returned and the driver of the protested car shall stand all expenses and be subject to penalty.
5. The Protest Committee shall hear the arguments of the protestee and the protestor, and by majority vote, shall determine the validity of the Protest and shall determine penalties for upheld protests which are appropriate to the seriousness of the offense. It is not necessary that every protest result in disqualification. The Protest Committee may deny any protest deemed to be spurious or a nuisance, particularly if it concerns non-performance affecting items. If a car is found to be improperly classified or to have unauthorized modifications, any penalties shall be assessed against all drivers of that car.

2001 Rules - Page 27



6. The event's Club Racing Competition Steward shall be the chairman of the event Protest Committee, and shall appoint two other committee members, one of whom may be the event's Technical Steward, shall appoint alternates, and shall prominently post their names at the event. The alternate(s) will act as a committee member if any member is involved in the protest or may otherwise have conflict of interest, or is not available.

Appeals

1. Decisions of the Protest Committee **or 13/13 Penalties** may be appealed to the Club Racing National Committee, consisting of the National Competition Steward and National Technical Steward, one Regional Competition Steward, one Regional Technical Steward, and one Advisory Committee member. An appeal shall be in writing, addressed to the BMW CCA National Competition Steward, shall be accompanied by a \$50.00 appeal fee, and shall reach the National Competition Steward within 14 days after the protest or 13/13 decision. It must specify the grounds for appeal and must contain the information that the appellant wishes to be considered in the appeal. The Club Racing National Committee will make the final decision whether or not the appeal is well- founded and should be heard, and whether the appeal fee should be returned or forfeited. Said decision shall be final, binding, and not subject to appeal. The fee shall be returned if the appeal is resolved in favor of the appellant, otherwise the fee will go to the Club Racing treasury. Any committee member who was involved in the initial protest or 13/13 penalty or may otherwise have a conflict of interest may not participate in the appeal discussion or vote. Appeal decisions will be decided by majority vote.

Rules Clarifications

1. The purpose of a Rules clarification is to resolve questions about the rules without recourse to an official protest against one entrant by another.
 - A. A rules clarification shall be made by the Club Racing Rules Committee.
 - B. A request may be made by any BMW CCA member who has entered a BMW CCA Club Racing event within a year prior to the request .

- C. A request for Rules Clarification shall be submitted in writing to any member of the Club Racing Rules Committee. The request shall cite the paragraph in question and shall be signed by the requestor.
- D. There shall be no charge for the request.
- E. A written reply shall be sent from the Club Racing Rules Committee to the requestor within 30 days of the request.
- F. A written Rules Clarification from the Club Racing Rules Committee is considered part of the current year rules and therefore may be used in future protest action. Such clarification shall be effective 30 days after publication and expire with publication of the next year's rules.

NOTE: Informal questions from current or prospective racers are welcome at any time. The Rules Clarification procedure facilitates formal inquiries or requested changes to the current rules.



RULE CHANGES

This section describes the method for updating and changing these rules. The Club Racing Rules Committee is responsible for this process as detailed in the following paragraphs. Ordinarily, there will be only one set of rules changes per year as specified below. These will become effective at the start of the next calendar year's season. Rules changes at other times are also specified below.

Club Racing Rules Committee

The Club Racing Rules Committee is comprised of the Club Racing Chairman, the National Competition Steward, the National Technical Steward, and one representative of the Club Racing Advisory Committee (CRAC) appointed by the CRAC by 7/1 and serving until 12/31 of the calendar year.

Club Racing Advisory Committee (CRAC)

The Club Racing Advisory Committee (CRAC) is comprised of members chosen yearly by a vote of the Club Racing participants from each region of the country. The regions are defined to be the same geographical areas as those defined for BMW CCA National Regions.

Rules Change Calendar

Prior to July 1 of each year, licensed Club Racing participants shall be invited (by CR newsletter or other means) to submit written requests and suggestions for rules updates for the next calendar year. The Club Racing Rules Committee shall review this input and, from these and other sources including the Club Racing Advisory Committee (CRAC), shall prepare a set of proposed rule changes. This proposal shall be published and distributed to licensed Club Racing participants, along with a request for comment.

Utilizing the responses, the Club Racing Rules Committee shall finalize and publish the rules changes.

July 15 - deadline to send rules change proposals to the Club Racing Rules Committee.

September CR newsletter - proposed changes printed and available for Racer comment/input..

December CR Newsletter - final rules changes printed. New rule books printed and distributed.

Changes in Mid-year

In exceptional circumstances it may be necessary to make rule changes in mid-year. For such changes, the Club Racing Rules Committee shall prepare a change proposal and review it with the CRAC. Based on the comments received, the Club Racing Rules Committee shall finalize the change and the rule change shall become effective on the date specified.



APPENDIX A - Roll Cage Specifications

All vehicles competing in the BMW CCA Club Racing program must be equipped with an approved roll cage. The main (rear) hoop must be securely mounted, either bolted or welded, to the floor and/or longitudinal members of the unibody with the top of the main hoop **as close to the roof as possible in closed cars** and at least 2" above the drivers helmet when the driver is seated in the normal driving position **in open cars**. The mounting area of the "bolt-in" roll cage must be backed by a plate of a size equal to that of the upper mounting plate with a minimum thickness of 3/16". Bolts must be grade 5 or higher. The roll cage must be mounted directly to the metal of the chassis and any padding, carpet, upholstery, etc., must be removed to satisfy this requirement. The roll cage must be full cockpit width, except as originally supplied by the factory for open race cars, and have two fore/aft braces of tubing size equal to the main hoop. The brace must be mounted as near the top of the hoop as possible and at an included angle of at least 30 degrees.

Additionally, the cage assembly must contain a transverse (horizontal, left to right side) brace which can be used for seatbelt harness mounting and as the attachment point for the seat back brace. An inspection hole 3/16" in diameter must be provided in a non-critical area for verification of tube thickness. Any portion of the cage which may come in contact with the driver's helmet must be covered with high density foam 1" thick held in place with electrical or duct tape or tie wraps.

The main and front hoops and fore and aft braces must have the following minimum diameter and wall thickness:

	Under 2500 lbs	Over 2500 lbs
Mild Steel	1.5" x .095"	1.75" x .095" or 1.50" x .120"
Alloy Steel	1.375" x .095"	1.50" x .095"

Other components of the roll cage need not have the same diameter and wall thickness as that of the required components.



It is strongly recommended that an experienced roll cage constructor be consulted in the cage design and installation. Any questions contact a BMW CCA Club Racing Technical Steward.

EXAMPLE ROLL CAGE SPECIFICATIONS

Strongly recommend minimum standard for all vehicles.

Tubing Joints - See Figures 2, 3, and 4

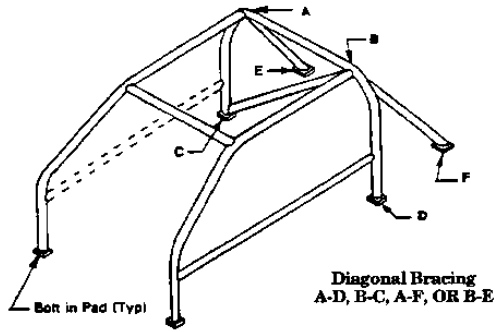

Figure 1



Figure 2

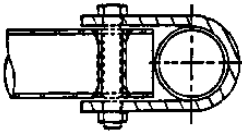

Figure 3

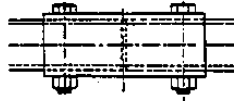

Figure 4

APPENDIX B – Electrical Disconnect Specifications

A standard electrical disconnect (battery cut-off) switch is strongly recommended on all cars competing in the BMW CCA Club Racing program and required for cars competing in Modified and Super Modified classes on full race tires, i.e. slicks. This switch must be wired such that electrical power to all circuits including alternator, except an electrically operated on-board fire system, is disconnected. In the interest of convenience, the switch may be mounted in the compartment near the battery and operation effected by a pull wire passing to the outside. The preferred location of the pull wire is on the driver's side. It must be clearly visible and its position marked with an approved decal of "lightening bolt" and the word "OFF". The decal can be placed on the window glass as opposed to the bodywork, as close as possible to the pull wire. It is recommended that the pull wire be painted red for visibility. Those vehicles with a permanently mounted switch or pull wire in another location will be allowed that alternate location providing the position is clearly marked with the approved decal and the switch or pull wire is easily accessible from outside the vehicle.

This requirement does not have to be viewed as a difficult one with which to comply and can very easily be accomplished with the fabrication of a simple bracket to hold the switch near the battery. Braided wire can be used for the pull and it should pass through a small bracket mounted inside the compartment. A loop in the end of the cable completes the installation. Pulling the cable rotates the switch and disconnects the battery from the circuit.

Appendix C - Minimum Weights

		STOCK	PREPARED
MAKE	YEARS	BMW FACTORY WEIGHT	ALLOWED WEIGHT W/ DRIVER
1600	66-71	2,072	2,060
2002	68-76	2,072	2,280
2002tii	71-74	2,183	2,310
E21 320i 2L	77-79	2,601	2,510
E21 320i 1.8L	80-83	2,396	2,360
E30 325e-es	84-87	2,723	2,614
E30 325i-is	87-91	2,811	2,750
E30 325ix	88-91	2,955	2,837
E30 318i	84-85	2,623	2,345
E30 M3	88-91	2,735	2,690
E30 318i-is	90-91	2,602	2,440
E36 318i-is	92	2,866	2,751
E36 318i-is	93-97	2,866	2,751
E36 318ti	95	2,734	2,625
E36 318ti	96-97	2,745	2,635
E36 325i-is	92	3,020	2,850
E36 325i-is	93-95	3,087	2,850
E36 328i-is	96-97	3,120	2,950
E36 M3	95-97	3,175	3,048
E36 M3 LTW	95	3,025	2,904
E36 323is	98	3,075	2,952
E46 323i	99	3,153	
E46 328i	99	3,197	
E46 325i	00	3,241	



E46 330i	01	3,318	
E46 330xi	01	3,527	
E46 M3	01	3,415	
M Roadster	98	3,084	2,961
M Coupe	99-00	3,131	
Z3 1.9L	96-97	2,690	2,582
Z3 2.8L	97	2,844	2,730
E12 528-530I	76-81	3,296	3,164
E28 528e	83-88	2,932	2,815
E28 533I	83	3,067	2,944
E28 535i-is	86-88	3,250	3,120
E28 M5	88	3,420	3,283
E34 525i (M20)	88-90	3,395	3,259
E34 525i (M50)	92-95	3,480	3,341
E34 535I	89-93	3,530	3,389
E34 M5	91-93	3,804	3,652
E24 633csi	79	3,516	3,375
E24 633csi	80-84	3,380	3,245
E24 635csi, L6	86-89	3,380	3,245
E24 M6	87-89	3,570	3,427

Appendix D - ENDURO SUPPLEMENTAL RULES

- An enduro is defined as a race of 60 minutes or more.
- All entrants must make a 5 minute timed pit stop (wheels must be stopped for five minutes). Each team is responsible for timing their own stop. Organizers may have additional personnel timing stops, but they are not obligated to provide timing for competitors.
Multiple stops during the race are allowed, but do not accrue towards the 5 minute requirement.
- The green flag and checkered flag cannot be taken in the pits unless the vehicle is experiencing a mechanical failure.
- All mandatory pit stops must be completed by the 50 minute mark of a 60 minute enduro
- **Mandatory Pit Lane Speed Limit 35 MPH (in and out)**

DRIVERS ARE REMINDED TO TEST BRAKES UPON LEAVING THE PITS !!!!!

- Driver changes are allowed during pit stops. Alternate drivers must be registered with the event and with Timing & Scoring for the entrant's results to be counted and to be eligible for drawings or points.
All drivers of record who have driven at least 25% of the scored laps are eligible for event sponsor drawings and points (if awarded). In the event of a shortened race, any registered driver who has not completed laps in the assigned car is not eligible for sponsor awards or points for that race.
- Re-fueling is allowed during pit stops, however any pit stop where re-fueling is done will be a minimum of 5 minutes in length.
 - Engines are to be off during fueling
 - Drivers and crew must be out of the car during fueling
 - Fueler must be protected by a flame retardant suit with no exposed skin. A balaclava or helmet with goggles, glasses, or shield is required.
 - A driver may be the fueler.
 - Each team must have a fireman with a minimum 10 pound fire extinguisher. The extinguisher pin must be pulled during fueling. Teams are responsible for providing extinguishers.

It is recommended that the fireman also be in a flame retardant suit with head and face protection. Minimally the fireman must have long pants, long shirt and eye protection. The fireman will stand behind and back from the fueler during fueling and will have **NO OTHER DUTIES EXCEPT FIREMAN DURING FUELING.**

- All crew in the hot pits will wear a fire retardant suit or long pants, long sleeved shirt (both cotton) and shoes.
- Maximum number of team members over the pit wall is 6 including driver(s).
- No smoking in the hot pits.
- No children 16 or younger in the hot pits.
- Rules in the event of shortened races –
 - **FULL COURSE YELLOW** - No pitting under a full course yellow. If an entrant is already in the pits when a full course yellow comes out, that entrant's pit stop may be continued.
 - **BLACK FLAG** - under Black Flag All conditions the 5 minute pit stop may be taken with service and driver changes allowed. The race clock does not stop.
 - **RED FLAG** - under Red flag conditions no pit stop activity is allowed (no service, no driver changes). The race clock will be stopped.
 - **Restarts** after Black Flag All or Red Flags will be single file based on the field order on the last full lap prior to the black flag all or red flag.
 - Cars which have not pitted for the 5 minute stop when the race is ended prematurely will be assessed a time/lap penalty equivalent to their fastest race lap plus 5 minutes.
 - Cars in the pits when the race is ended prematurely will receive a pit time which is the greater of the actual time in the pits or their fastest race lap plus 5 minutes.